



Coimisiún na Scrúduithe Stáit
State Examinations Commission

Leaving Certificate 2013

Marking Scheme

Mathematics
(Project Maths – Phase 3)

Ordinary Level

Note to teachers and students on the use of published marking schemes

Marking schemes published by the State Examinations Commission are not intended to be standalone documents. They are an essential resource for examiners who receive training in the correct interpretation and application of the scheme. This training involves, among other things, marking samples of student work and discussing the marks awarded, so as to clarify the correct application of the scheme. The work of examiners is subsequently monitored by Advising Examiners to ensure consistent and accurate application of the marking scheme. This process is overseen by the Chief Examiner, usually assisted by a Chief Advising Examiner. The Chief Examiner is the final authority regarding whether or not the marking scheme has been correctly applied to any piece of candidate work.

Marking schemes are working documents. While a draft marking scheme is prepared in advance of the examination, the scheme is not finalised until examiners have applied it to candidates' work and the feedback from all examiners has been collated and considered in light of the full range of responses of candidates, the overall level of difficulty of the examination and the need to maintain consistency in standards from year to year. This published document contains the finalised scheme, as it was applied to all candidates' work.

In the case of marking schemes that include model solutions or answers, it should be noted that these are not intended to be exhaustive. Variations and alternatives may also be acceptable. Examiners must consider all answers on their merits, and will have consulted with their Advising Examiners when in doubt.

Future Marking Schemes

Assumptions about future marking schemes on the basis of past schemes should be avoided. While the underlying assessment principles remain the same, the details of the marking of a particular type of question may change in the context of the contribution of that question to the overall examination in a given year. The Chief Examiner in any given year has the responsibility to determine how best to ensure the fair and accurate assessment of candidates' work and to ensure consistency in the standard of the assessment from year to year. Accordingly, aspects of the structure, detail and application of the marking scheme for a particular examination are subject to change from one year to the next without notice.

Contents

Page

Paper 1

Model Solutions	3
Marking Scheme	18
Structure of the marking scheme	18
Summary of mark allocations and scales to be applied	19
Detailed marking notes	20

Paper 2

Model Solutions	31
Marking Scheme	50
Structure of the marking scheme	50
Summary of mark allocations and scales to be applied	51
Detailed marking notes	52
Marcanna breise as ucht freagairt trí Gaeilge	63

Blank Page



Coimisiún na Scrúduithe Stáit
State Examinations Commission

Leaving Certificate Examination, 2013

Mathematics (Project Maths – Phase 3)

Paper 1

Ordinary Level

Friday 7 June Afternoon 2:00 – 4:30

300 marks

Model Solutions – Paper 1

Note: The model solutions for each question are not intended to be exhaustive – there may be other correct solutions. Any examiner unsure of the validity of the approach adopted by a particular candidate to a particular question should contact his / her advising examiner.

Instructions

There are **two** sections in this examination paper.

Section A	Concepts and Skills	150 marks	6 questions
Section B	Contexts and Applications	150 marks	3 questions

Answer all nine questions.

Write your answers in the spaces provided in this booklet. You may lose marks if you do not do so. You may also ask the superintendent for more paper. Label any extra work clearly with the question number and part.

The superintendent will give you a copy of the *Formulae and Tables* booklet. You must return it at the end of the examination. You are not allowed to bring your own copy into the examination.

Marks will be lost if all necessary work is not clearly shown.

Answers should include the appropriate units of measurement, where relevant.

Answers should be given in simplest form, where relevant.

Write the make and model of your calculator(s) here:

Answer **all six** questions from this section.

Question 1

(25 marks)

Let $z_1 = 3 - 4i$ and $z_2 = 1 + 2i$, where $i^2 = -1$.

(a) Plot z_1 and z_2 on the Argand diagram over.

(b) From your diagram, is it possible to say that $|z_1| > |z_2|$?

Give the reason for your answer.

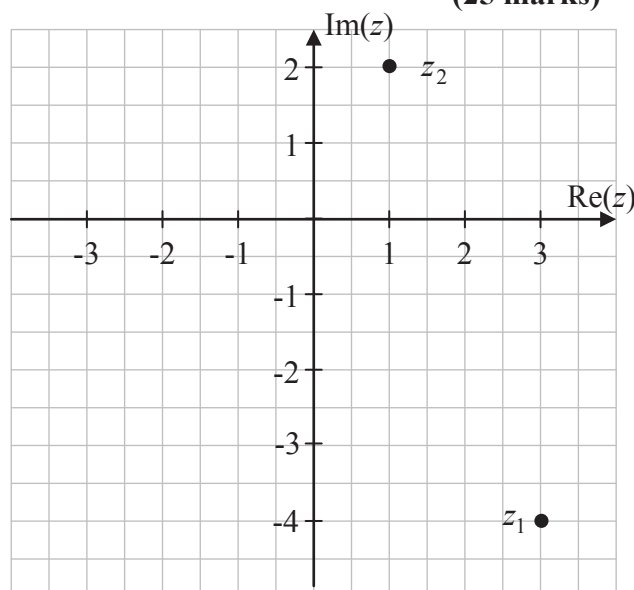

Answer: Yes

Reason: The distance from the origin to z_1 is greater than the distance from the origin to z_2 .

(c) Verify algebraically that $|z_1| > |z_2|$.

$$|z_1| = |3 - 4i| = \sqrt{3^2 + (-4)^2} = \sqrt{9 + 16} = \sqrt{25} = 5$$

$$|z_2| = |1 + 2i| = \sqrt{1^2 + 2^2} = \sqrt{1 + 4} = \sqrt{5}$$

$$5 > \sqrt{5} \Rightarrow |z_1| > |z_2|$$

(d) Find $\frac{z_1}{z_2}$ in the form $x + yi$, where $x, y \in \mathbb{R}$.

$$\frac{z_1}{z_2} = \frac{3 - 4i}{1 + 2i} = \frac{3 - 4i}{1 + 2i} \times \frac{1 - 2i}{1 - 2i} = \frac{3 - 6i - 4i + 8i^2}{1^2 + 2^2} = \frac{-5 - 10i}{5} = -1 - 2i$$

Question 2**(25 marks)**

The diagram shows the graph of the function $f(x) = 6x - x^2$ in the domain $0 \leq x \leq 6$, $x \in \mathbb{R}$.

- (a) Find $f(0)$, $f(1)$, $f(2)$, $f(3)$, $f(4)$, $f(5)$ and $f(6)$. Hence, complete the table below.

x	0	1	2	3	4	5	6
$f(x)$	0	5	8	9	8	5	0

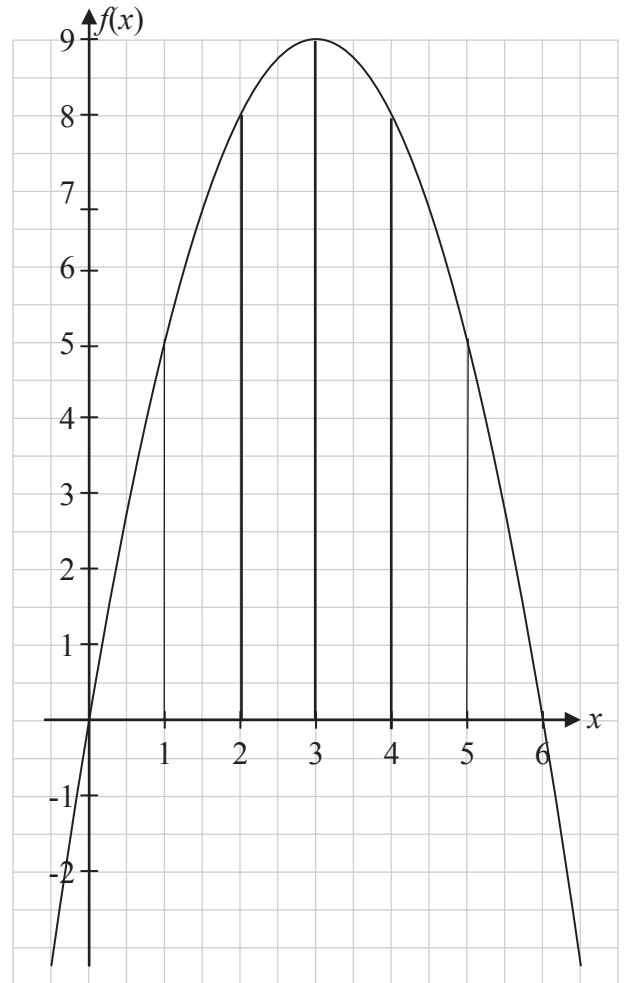

$$f(x) = 6x - x^2$$

$$f(0) = 6(0) - 0^2 = 0$$

$$f(1) = 6(1) - 1^2 = 5$$

$$f(2) = 6(2) - 2^2 = 8$$

$$f(3) = 6(3) - 3^2 = 9$$

$$f(4) = 6(4) - 4^2 = 8$$

$$f(5) = 6(5) - 5^2 = 5$$

$$f(6) = 6(6) - 6^2 = 0$$

- (b) Use the trapezoidal rule to estimate the area of the region enclosed between the curve and the x -axis in the given domain.

$$\begin{aligned}
 A &\approx \frac{h}{2} [y_1 + y_n + 2(y_2 + y_3 + y_4 + \dots + y_{n-1})] \\
 &= \frac{1}{2} [0 + 0 + 2(5 + 8 + 9 + 8 + 5)] \\
 &= 35
 \end{aligned}$$

Question 3

(25 marks)

- (a) The mean distance from the earth to the sun is 149 597 871 km. Write this number in the form $a \times 10^n$, where $1 \leq a < 10$ and $n \in \mathbb{Z}$, correct to two significant figures.

$$149\,597\,871 \approx 1.5 \times 10^8 \text{ km}$$

- (b) (i) Write each of the numbers below as a decimal correct to two decimal places.

	A	B	C	D	E	F	G
Number	2.1	$\sqrt{5}$	$\frac{243}{85}$	$\tan 70^\circ$	$\frac{3\pi}{4}$	250%	$\left(1 + \frac{1}{10}\right)^{10}$
Decimal Number	2.10	2.24	2.86	2.75	2.36	2.50	2.59

- (ii) Mark 5 of the numbers in the table on the number line below and label each number clearly.

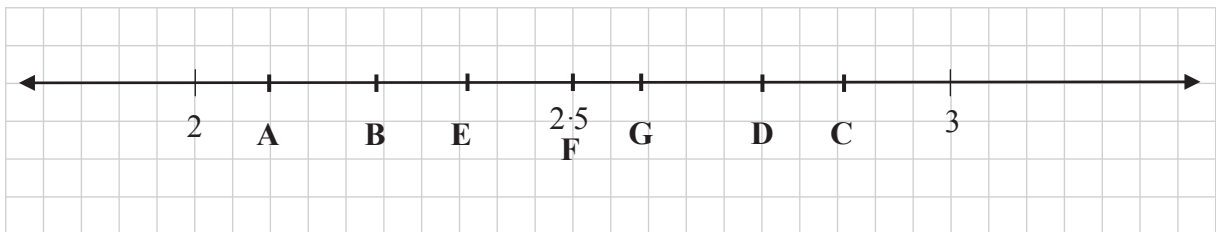

- (c) Solve the equation $27^{2x} = 3^{x+10}$.

$$\begin{aligned}
 27^{2x} &= 3^{x+10} \\
 \Rightarrow (3^3)^{2x} &= 3^{x+10} \\
 \Rightarrow 3^{6x} &= 3^{x+10} \\
 \Rightarrow 6x &= x+10 \Rightarrow 5x = 10 \Rightarrow x = 2
 \end{aligned}$$

Question 4**(25 marks)**

- (a) Given that $R = (1 + 0 \cdot 015)^{12}$, find the value of R , correct to 2 decimal places.

$$R = (1 + 0 \cdot 015)^{12} = 1 \cdot 015^{12} = 1 \cdot 1956... \approx 1 \cdot 20$$

- (b) Michael has a credit card with a credit limit of €1000. Interest is charged monthly at 1·5% of the amount owed. Michael gets a bill at the end of each month. At the start of January, Michael owes €800 on his credit card. If Michael makes no repayments and no more purchases, show that he will exceed his credit limit after 15 months.

$$\begin{aligned} F &= P(1+i)^t \\ &= 800(1+0 \cdot 015)^{15} \\ &= 800(1 \cdot 015)^{15} \\ &= 1000 \cdot 18... \\ \text{€}1000 \cdot 18... &> \text{€}1000 \end{aligned}$$

- (c) Michael buys an item costing £95 on the internet and pays with his credit card. If the exchange rate is €1 = £0.8473, calculate, correct to the nearest cent, the amount that will be included on Michael's credit card bill.

$$\frac{95}{0.8473} = 112.1208... \approx \text{€}112.12$$

Question 5**(25 marks)**

- (a) Let $y = 2x^3 - 3x^2 - 1$. Find $\frac{dy}{dx}$.

$$y = 2x^3 - 3x^2 - 1 \Rightarrow \frac{dy}{dx} = 6x^2 - 6x.$$

- (b) Differentiate $(2x^2 + 3x + 1)(x^3 - x + 2)$ with respect to x .

$$\begin{aligned} y &= (2x^2 + 3x + 1)(x^3 - x + 2) \\ \text{Let } u &= 2x^2 + 3x + 1 \Rightarrow \frac{du}{dx} = 4x + 3 \\ \text{Let } v &= x^3 - x + 2 \Rightarrow \frac{dv}{dx} = 3x^2 - 1 \\ \frac{dy}{dx} &= u \frac{dv}{dx} + v \frac{du}{dx} \\ &= (2x^2 + 3x + 1)(3x^2 - 1) + (x^3 - x + 2)(4x + 3) \\ &= 6x^4 - 2x^2 + 9x^3 - 3x + 3x^2 - 1 + 4x^4 + 3x^3 - 4x^2 - 3x + 8x + 6 \\ &= 10x^4 + 12x^3 - 3x^2 + 2x + 5 \end{aligned}$$

- (c) Let $y = \frac{3x}{2x+5}$, where $2x+5 \neq 0$. Find the value of $\frac{dy}{dx}$ at $x = 0$.

$$\begin{aligned} y &= \frac{3x}{2x+5} \\ \text{Let } u &= 3x \Rightarrow \frac{du}{dx} = 3 \\ \text{Let } v &= 2x+5 \Rightarrow \frac{dv}{dx} = 2 \\ \frac{dy}{dx} &= \frac{v \frac{du}{dx} - u \frac{dv}{dx}}{v^2} \\ &= \frac{(2x+5)(3) - (3x)(2)}{(2x+5)^2} \\ &= \frac{(0+5)(3) - (0)(2)}{(0+5)^2} = \frac{15-0}{25} = \frac{3}{5} \text{ at } x = 0 \end{aligned}$$

Question 6**(25 marks)**

The diagram opposite shows graphs of the quadratic function $f(x) = x^2 + 3x - 1$, $x \in \mathbb{R}$ and the line l_1 . The line l_1 passes through the point $(2, 0)$ and is a tangent to the curve at the point $(-1, -3)$.

- (a) Find the slope of l_1 , using a slope formula.

$$\text{Slope} = \frac{-3 - 0}{-1 - 2} = \frac{-3}{-3} = 1$$

- (b) (i) Find $f'(x)$, the derivative of $f(x)$.

$$f(x) = x^2 + 3x - 1$$

$$f'(x) = 2x + 3$$

- (ii) Verify your answer to (a) above by finding the value of $f'(x)$ at $x = -1$.

$$f'(x) = 2x + 3 \Rightarrow f'(-1) = 2(-1) + 3 = 1 \text{ at } x = -1$$

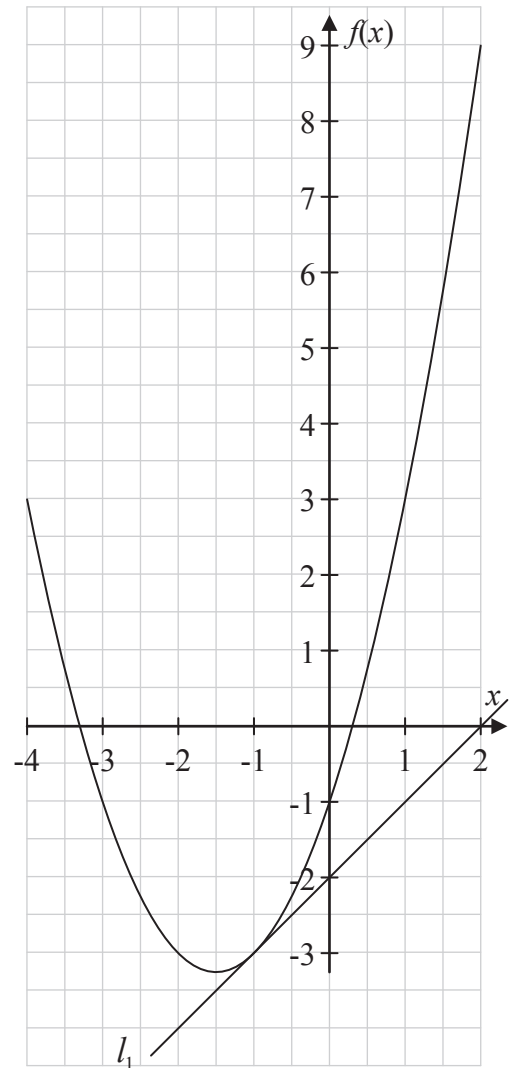

- (c) The line l_2 is perpendicular to l_1 and is also a tangent to the curve $f(x)$. Find the co-ordinates of the point at which l_2 touches the curve.

$$l_1 \perp l_2: \text{ Slope of } l_1 = 1 \Rightarrow \text{ slope of } l_2 = -1$$

$$f'(x) = 2x + 3 = -1 \Rightarrow 2x = -4 \Rightarrow x = -2$$

$$f(x) = x^2 + 3x - 1 \Rightarrow f(-2) = (-2)^2 + 3(-2) - 1 = -3$$

Point of contact $(-2, -3)$

Answer **all three** questions from this section.

Question 7**(40 marks)**

Two identical cylindrical tanks, A and B, are being filled with water. At a particular time, the water in tank A is 25 cm deep and the depth of the water is increasing at a steady rate of 5 cm every 10 seconds. At the same time the water in tank B is 10 cm deep and the depth of the water is increasing at a steady rate of 7.5 cm every 10 seconds.

- (a) Draw up a table showing the depth of water in each tank at 10 second intervals over two minutes, beginning at the time mentioned above.

Time (s)	0	10	20	30	40	50	60	70	80	90	100	110	120
Tank A	25	30	35	40	45	50	55	60	65	70	75	80	85
Tank B	10	17.5	25	32.5	40	47.5	55	62.5	70	77.5	85	92.5	100

- (b) Each tank is 1 m in height. Find how long it takes to fill each tank.

Tank A: 2 minutes 30 seconds

Tank B: 2 minutes

- (c) For each tank, write down a formula which gives the depth of water in the tank at any given time. State clearly the meaning of any letters used in your formulas.

Tank A: $d = 25 + \frac{5}{10}t = 25 + \frac{1}{2}t$ where d is the depth in cm at time t seconds

Tank B: $d = 10 + \frac{3}{4}t$

- (d) For each tank, draw the graph to represent the depth of water in the tank over the 2 minutes.

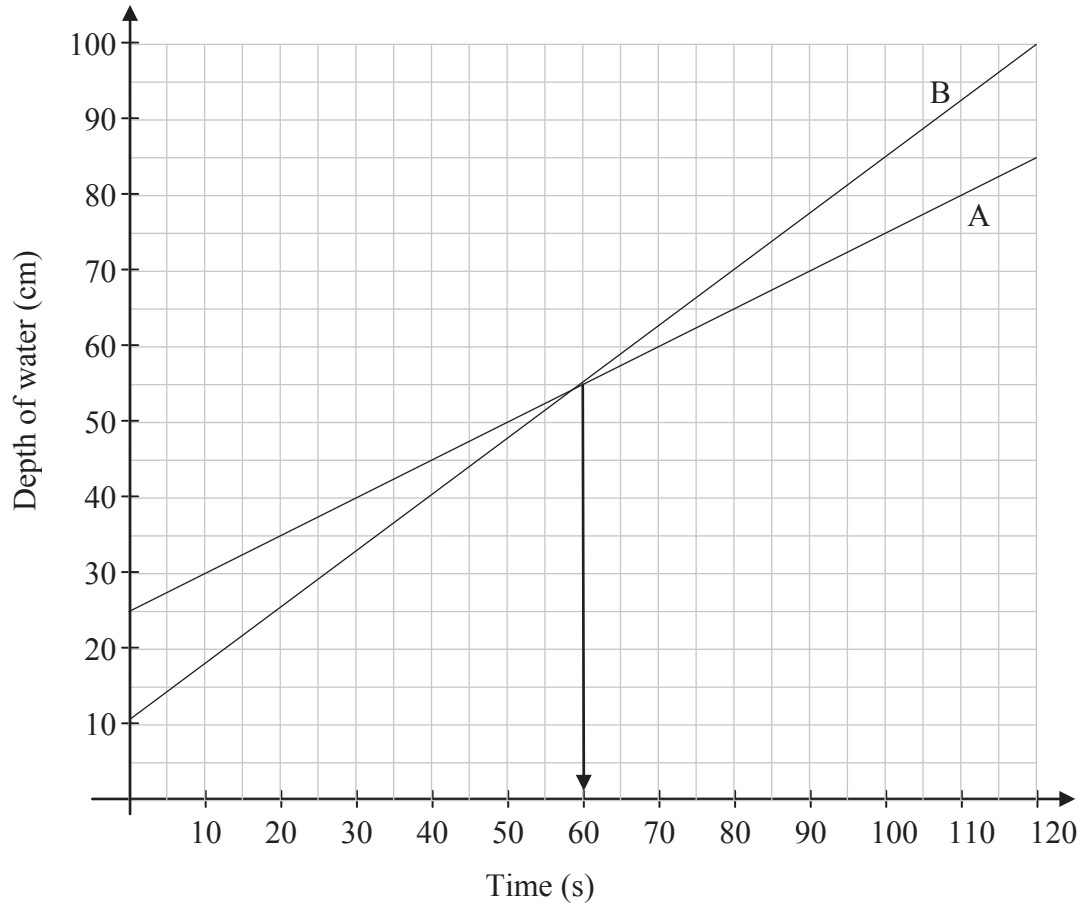

- (e) Find, from your graphs, how much time passes before the depth of water is the same in each tank.

Answer: 60 seconds

- (f) Verify your answer to part (e) using your formulas from part (c).

$$d = 25 + \frac{1}{2}t = 10 + \frac{3}{4}t \Rightarrow \frac{1}{4}t = 15 \Rightarrow t = 60 \text{ seconds}$$

Question 8**(60 marks)**

Two brothers, Eoin and Peter, began work in 2005 on starting salaries of €20 000 and €17 000 per annum, respectively. Eoin's salary increased by €500 per annum and Peter's salary increased by €1250 per annum. This salary pattern will continue.

(a) Complete the table, showing the annual salary of each brother for the years 2005 to 2010.

Year	1	2	3	4	5	6
Eoin's salary (€)	20 000	20 500	21 000	21 500	22 000	22 500
Peter's salary (€)	17 000	18 250	19 500	20 750	22 000	23 250

(b) In what year will both brothers earn the same amount?

Answer: 2009

(c) Eoin claims that their salaries over the years can be represented by an arithmetic sequence.

(i) Explain what an arithmetic sequence is.

A sequence in which the difference between any two successive terms is a constant.

(ii) Do you agree with Eoin? Explain your answer.

Answer: Yes.

A constant amount is added to his salary in any year to give his salary for the following year.

(d) Find, in terms of n , a formula that gives Eoin's salary in the n^{th} year of the pattern.

$$T_n = 20\,000 + (n - 1)500 = 19\,500 + 500n$$

(e) Using your formula, or otherwise, find Eoin's salary in 2015.

$$\begin{aligned} 2015: \quad n &= 11 \\ T_{11} &= 19\,500 + 500(11) = \text{€}25\,000 \end{aligned}$$

- (f) Find, in terms of n , a formula that gives the total amount earned by Peter from the first to the n^{th} year of the pattern.

The first term: 17 000
 The common difference: 1250

$$S_n = \frac{n}{2}(2a + (n-1)d) = \frac{n}{2}(34\,000 + (n-1)1250) = 625n^2 + 16375n$$

- (g) Using your formula, or otherwise, find the total amount earned by Peter from the start of 2005 up to the end 2015.

$$S_n = 625n^2 + 16375n = 625(11)^2 + 16375(11) = 75\,625 + 180\,125 = \text{€}255\,750$$

or

$$S_n = \frac{n}{2}(2a + (n-1)d)$$

$$S_{11} = \frac{11}{2}(34\,000 + (11-1)1250) = \frac{11}{2}(34\,000 + 12\,500) = \text{€}255\,750$$

- (h) Give one reason why the graph below is not an accurate way to represent Peter's salary over the period 2005 to 2011.

The graph shows Peter's salary increasing constantly throughout the year which is not true.

Peter's salary increases in steps at the end of each year and the graph does not reflect this.

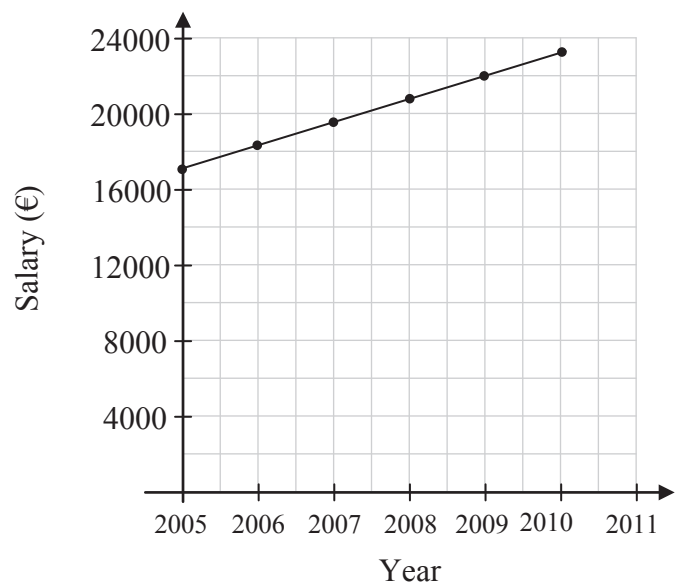

Question 9**(50 marks)**

A company has calculated that the daily cost (in euro) to produce x items is given by the production cost function $C(x) = 5x^2 + 750x + 3000$. The total daily income from the sale of x items is given by the revenue function $R(x) = 1200x$.

The company assumes that it will sell all the items it produces.

- (a) The company produces 20 items in one day. Find the production cost and total income for the 20 items.

Production cost:	$C(x) = 5x^2 + 750x + 3000$ $\Rightarrow C(20) = 5(20)^2 + 750(20) + 3000 = \text{€}20\,000$
Total income:	$R(x) = 1200x$ $\Rightarrow R(20) = 1200(20) = \text{€}24\,000$

- (b) Find the profit the company makes on that day.

Profit:	$R(20) - C(20) = 24000 - 20000 = \text{€}4000$
---------	--

- (c) Find a general expression for the profit the company makes from the production of x items.

Profit:	$P(x) = R(x) - C(x) = 1200x - (5x^2 + 750x + 3000)$ $\Rightarrow P(x) = -5x^2 + 450x - 3000$
---------	---

- (d) How many of these items will the company have to produce and sell in order to make a maximum profit?

$P(x) = -5x^2 + 450x - 3000$ $\Rightarrow P'(x) = -10x + 450$ $P'(x) = 0 \Rightarrow -10x + 450 = 0$ $\Rightarrow x = 45$
--

- (e) Find the maximum profit the company can make.

$P(x) = -5x^2 + 450x - 3000$ $P(45) = -5(45)^2 + 450(45) - 3000 = -10125 + 20250 - 3000 = \text{€}7125$
--

- (f) The production costs on a particular day amount to €11 000. Find number of items produced on that day.

$$C(x) = 5x^2 + 750x + 3000 = 11000$$

$$\Rightarrow 5x^2 + 750x - 8000 = 0$$

$$\Rightarrow x^2 + 150x - 1600 = 0$$

$$\Rightarrow (x - 10)(x + 160)$$

$$\Rightarrow x = 10 \text{ or } x = -160$$

Answer: 10 items

Or

$$C(x) = 5x^2 + 750x + 3000$$

Let $x = 10$

$$C(10) = 5(10)^2 + 750(10) + 3000$$

$$= 500 + 7500 + 3000$$

$$= 11000$$

The production costs amount to €11 000 when 10 items are produced.

Marking Scheme – Paper 1, Section A and Section B

Structure of the marking scheme

Candidate responses are marked according to different scales, depending on the types of response anticipated. Scales labelled A divide candidate responses into two categories (correct and incorrect). Scales labelled B divide responses into three categories (correct, partially correct, and incorrect), and so on. The scales and the marks that they generate are summarised in this table:

Scale label	A	B	C	D
No of categories	2	3	4	5
5 mark scales	0, 5	0, 2, 5	0, 2, 4, 5	
10 mark scales		0, 5, 10	0, 3, 7, 10	0, 2, 5, 8, 10
15 mark scales			0, 5, 10, 15	0, 4, 7, 11, 15
25 mark scales			0, 8, 17, 25	

A general descriptor of each point on each scale is given below. More specific directions in relation to interpreting the scales in the context of each question are given in the scheme, where necessary.

Marking scales – level descriptors

A-scales (two categories)

- incorrect response
- correct response

B-scales (three categories)

- response of no substantial merit
- partially correct response
- correct response

C-scales (four categories)

- response of no substantial merit
- response with some merit
- almost correct response
- correct response

D-scales (five categories)

- response of no substantial merit
- response with some merit
- response about half-right
- almost correct response
- correct response

In certain cases, typically involving incorrect rounding or omission of units, a mark that is one mark below the full-credit mark may also be awarded. Such cases are flagged with an asterisk. Thus, for example, *scale 10C** indicates that 9 marks may be awarded.

Summary of mark allocations and scales to be applied

Section A

Question 1	
(a)	5C
(b)	5C
(c)	5C
(d)	10C*
Question 2	
(a)	10D
(b)	15C
Question 3	
(a)	5B*
(b)(i)	5C
(b)(ii)	5C
(c)	10C
Question 4	
(a)	5B*
(b)	10C
(c)	10B*
Question 5	
	25C
Question 6	
(a)	5C
(b)(i)	10C
(b)(ii)	5C
(c)	5C

Section B

Question 7	
(a)	10D
(b)	5B*
(c)	5B
(d)	10C
(e)	5B*
(f)	5C
Question 8	
(a)	15D
(b)	5A
(c)(i)	5B
(c)(ii)	5B
(d)	5B
(e)	10C
(f)	5C
(g)	5C
(h)	5B
Question 9	
(a)	15C
(b)	10B
(c)	5B
(d)	5C
(e)	5B
(f)	10D

Detailed marking notes

Section A

Question 1

(a) Scale 5C (0, 2, 4, 5)

Low partial credit:

- A correct real or imaginary part plotted for either point.
- Both numbers plotted correctly but real and imaginary axes interchanged.

High partial credit:

- Plots one point correctly.

(b) Scale 5C (0, 2, 4, 5)

Low partial credit:

- Correct answer given without a reason or reason given is without merit.
- Answer not given, or incorrect, but some merit in the reason such as reference to distance.

High partial credit:

- Correct answer with a reason given that refers to distance.
- A fully correct reason without an answer given.

(c) Scale 5C (0, 2, 4, 5)

Low partial credit:

- Correct modulus formula written.
- Each point joined to origin.
- Use of z_1 or z_2 .

High partial credit:

- One modulus value calculated correctly.
- Correct substitution into formula for both numbers but neither value correct.

Note: Both modulus values correct, without comparison shown, award full credit.

(d) Scale 10C* (0, 3, 7, 10)

Low partial credit:

- Correct substitution for z_1 and/or z_2 .

High partial credit:

- Multiplication above and below by correct conjugate shown and some subsequent work.

* Penalise one mark for not writing correct answer in the form $-1 - 2i$.

Question 2

(a) Scale 10D (0, 2, 5, 8, 10)

Low partial credit:

- One or two correct values only in the table.

Middle partial credit:

- Three or four correct values only in the table.

High partial credit:

- Five or six correct values in the table.

(b) Scale 15C (0, 5, 10, 15)

Low partial credit:

- Writes the correct trapezoidal rule, without further work of merit.
- Simpson's rule with substantially correct substitution and calculation.

High partial credit:

- Trapezoidal rule with correct substitution.
- Trapezoidal rule with incorrect substitution (maximum of 2) with correct calculation.
- Correct answer without work shown.

Note: Formula and correct answer, without work shown, award full credit.

Question 3

(a) Scale 5B* (0, 2, 5)

Partial credit:

- Either a (unrounded) or n correct.

* Penalise one mark for incorrect or omitted round-off, provided full marks otherwise.

(b)(i) Scale 5C (0, 2, 4, 5)

Low partial credit:

- One or two numbers only (other than A) written correctly.

High partial credit:

- Three, four or five numbers only (other than A) written correctly.

(b)(ii) Scale 5C (0, 2, 4, 5)

Low partial credit:

- One or two numbers only plotted correctly.

High partial credit:

- Three or four numbers only plotted correctly.

(c) Scale 10C (0, 3, 7, 10)

Low partial credit:

- Some work of merit with indices.
- Some work of merit in solving linear equation.
- Solves the equation $2x = x + 10$ correctly.
- Correct answer without work shown.

High partial credit:

- Correct equation in indices set up but fails to finish correctly.
- Incorrect equation in indices but solves “equation of indices” correctly.

Note: Correct answer by trial and improvement, shown for both sides, award full credit.

Question 4

(a) Scale 5B* (0, 2, 5)

Partial credit:

- Some work of merit e.g. $1 \cdot 015$.
- Multiplies by 12.
- Accept $(1 \cdot 15)^{12} = 5 \cdot 3502\dots$ or $(1 \cdot 0015)^{12} = 1 \cdot 0181\dots$ with or without work shown.

* Penalise one mark for incorrect or omitted round-off, provided full marks otherwise.

(b) Scale 10C (0, 3, 7, 10)

Low partial credit:

- Writes correct formula without further work of merit.
- Some correct substitution into an incorrect formula, e.g. depreciation.
- Calculates 1.5% of an amount correctly.

High partial credit:

- Correct substitution into correct formula but error in calculations.
- Calculates the amount at the end of each of 15 months, but with minor errors.

(c) Scale 10B* (0, 5, 10)

Partial credit:

- Writes $\frac{95}{0.8473}$ and stops.
- Gives an answer of €80.49 with or without work shown.

Note: Correct answer without work shown, award full credit.

* Penalise one mark for incorrect or omitted round-off, provided full marks otherwise.

Question 5

Scale 25C (0, 8, 17, 25)

This question required a range of skills, only some of which are on the syllabus for these candidates. Marking focuses only on the syllabus-related skills.

Low partial credit:

- Displays syllabus related skills, e.g. correct differentiation of one term only.

High partial credit:

- Correct differentiation of two terms only.
- Correct coefficient for each term but error(s) in indices.
- Correct indices for each term but error(s) in coefficients.

Note: Consistently displays syllabus-related skills, e.g. three terms correctly differentiated, award full credit.

Question 6

(a) Scale 5C (0, 2, 4, 5)

Low partial credit:

- Inverted slope formula with otherwise correct work.
- Correct formula with errors in substitution.

High partial credit:

- Correct substitution with errors in simplification.

(b)(i) Scale 10C (0, 3, 7, 10)

Low partial credit:

- Correct differentiation of one term only.

High partial credit:

- Correct differentiation of two terms only.
- Correct coefficient for each term but error(s) in indices.
- Correct indices for each term but error(s) in coefficients.

(b)(ii) Scale 5C (0, 2, 4, 5)

Low partial credit:

- Shows $f(-1) = -3$.
- Substitutes $x = -1$ into $f'(x)$ and stops.
- Error in substitution into derivative.

High partial credit:

- Correct substitution with errors in simplification.

(c) Scale 5C (0, 2, 4, 5)

Low partial credit:

- Attempt at finding slope of l_2 .
- Attempts to work with $f'(x)$.
- Correct answer without work shown.
- Finds the x co-ordinate only, graphically.

High partial credit:

- Finds the x co-ordinate only of the point of contact, using differentiation.
- Correct answer obtained graphically.

Section B

Question 7

(a) Scale 10D (0, 2, 5, 8, 10)

Low partial credit:

- Table for one tank with two correct entries.

Middle partial credit:

- Table for one tank correct.
- Table for two tanks correct for 1 minute.

High partial credit:

- Four terms or less missing or incorrect, allowing for consistent terms.
- Tables which begin with $A(10) = 25$ and $B(10) = 10$ and continue correctly.
- Tables which begin with $A(0) = 0$ and $B(0) = 0$ and continue correctly.

Note 1: Accept tables which are fully correct but do not include the values at $t = 0$.

Note 2: Accept answers in (b), (c) and (d) based on candidate's tables.

(b) Scale 5B* (0, 2, 5)

Partial credit:

- One correct answer.

* Penalise one mark for incorrect or omitted units, provided full marks otherwise.

(c) Scale 5B (0, 2, 5)

Partial credit:

- Writes $T_n = a + (n - 1)d$.
- Some work at setting up a formula.

(d) Scale 10C (0, 3, 7, 10)

Low partial credit:

- Correct point plotted for one line.
- A line of some relevance drawn.

High partial credit:

- One graph fully correct or both graphs substantially correct.
- Correct graphs drawn freehand.

Note: Accept answers in (e) and (f) based on candidate's graph.

(e) Scale 5B* (0, 2, 5)

Partial credit:

- Point of intersection identified.
- Answer indicated on axis but value not written.

* Penalise one mark for incorrect or omitted units, provided full marks otherwise.

(f) Scale 5C (0, 2, 4, 5)

Low partial credit:

- Formulae written but not equated.

High partial credit:

- Error in solving equation.
- Substitutes correctly into one formula only.

Question 8

(a) Scale 15D (0, 4, 7, 11, 15)

Low partial credit:

- One correct entry.

Middle partial credit:

- Errors in three or more terms, allowing for consistent errors.

High partial credit:

- Errors in two or less terms, allowing for consistent errors.

(b) Scale 5A (0, 5)

Note: Accept answers based on candidate's work.

(c)(i) Scale 5B (0, 2, 5)

Partial credit:

- Shows some understanding of an arithmetic sequence.

(c)(ii) Scale 5B (0, 2, 5)

Partial credit:

- Correct answer without valid explanation.
- Correct explanation without giving an answer.

(d) Scale 5B (0, 2, 5)

Partial credit:

- Correctly identifies a or d for Eoin's salary.
- Correctly identifies a and d for Peter's salary.
- Writes $T_n = a + (n - 1)d$.

(e) Scale 10C (0, 3, 7, 10)

Low partial credit:

- Finds the correct value of n and stops.
- Continues the pattern for one more term.
- Attempts substitution into candidate's formula.
- Some merit in work with the general term.

High partial credit:

- Continues pattern correctly but stops at the tenth year.
- Substitutes $n = 10$ into formula and calculates answer.

(f) Scale 5C (0, 2, 4, 5)

Low partial credit:

- Writes $S_n = \frac{n}{2}[2a + (n-1)d]$ or other valid formula.
- Identifies a or d for Peter's salary.
- Identifies a and d for Eoin's salary.

High partial credit:

- A correct formula substituted, except for one error, for Peter.
- A correct formula applied to Eoin's data, correctly.

(g) Scale 5C (0, 2, 4, 5)

Note: Accept candidate's answers from (f).

Low partial credit:

- Finds the correct value of n and stops.
- Continues the pattern for one more term.
- Attempts substitution into candidate's formula.
- Some merit in work with the S_n formula.
- Uses Eoin's data incorrectly.

High partial credit:

- Continues the pattern correctly to 2015 but doesn't add the terms.
- Continues the pattern incorrectly (stops at $n = 10$ or one error with consistent terms) but adds the terms.
- Substitutes $n = 10$ into formula and calculates answer.
- Substitutes correctly into formula but doesn't calculate answer.
- Uses Eoin's data correctly.

(h) Scale 5B (0, 2, 5)

Partial credit:

- A reason with some merit.

Question 9

(a) Scale 15C (0, 5, 10, 15)

Low partial credit:

- Some correct substitution into either function.

High partial credit:

- Substantially correct substitution and calculation.

(b) Scale 10B (0, 5, 10)

Note: Accept candidate's work from previous section.

Partial credit:

- Any correct relevant step.

(c) Scale 5B (0, 2, 5)

Partial credit:

- Relevant work such as writing $R(x) - C(x)$.
- Mishandles subtraction.

(d) Scale 5C (0, 2, 4, 5)

Low partial credit:

- Relevant trial and improvement work.
- Differentiation with error(s) and stops.

High partial credit:

- Correct differentiation without further work.
- Substantially correct differentiation with attempt to solve $P'(x) = 0$.

(e) Scale 5B (0, 2, 5)

Note: Accept candidate's answer from previous section.

Partial credit:

- Attempts to calculate $P(45)$.
- Trial and improvement work, different from part (d).

(f) Scale 10D (0, 2, 5, 8, 10)

Low partial credit:

- Recognises $C(x) = 11\,000$.
- Substitutes a value for x into $C(x)$.

Middle partial credit:

- Substantially correct approach to solving quadratic equation.
- Correct answer without any work.

High partial credit:

- Solves equation but fails to identify correct answer.
- Substitutes $x = 10$ into $C(x)$ but fails to show answer is €11 000.



Coimisiún na Scrúduithe Stáit
State Examinations Commission

Leaving Certificate Examination, 2013

Mathematics
(Project Maths – Phase 3)

Paper 2

Ordinary Level

Monday 10 June Morning 9:30 – 12:00

300 marks

Model Solutions – Paper 2

Note: The model solutions for each question are not intended to be exhaustive – there may be other correct solutions. Any examiner unsure of the validity of the approach adopted by a particular candidate to a particular question should contact his / her advising examiner.

Instructions

There are **two** sections in this examination paper.

Section A	Concepts and Skills	150 marks	6 questions
Section B	Contexts and Applications	150 marks	2 questions

Answer all eight questions, as follows:

In Section A, answer:

Questions 1 to 5 and

either Question 6A **or** Question 6B.

In Section B, answer Question 7 and Question 8.

Write your answers in the spaces provided in this booklet. You may lose marks if you do not do so. You may also ask the superintendent for more paper. Label any extra work clearly with the question number and part.

The superintendent will give you a copy of the *Formulae and Tables* booklet. You must return it at the end of the examination. You are not allowed to bring your own copy into the examination.

Marks will be lost if all necessary work is not clearly shown.

Answers should include the appropriate units of measurement, where relevant.

Answers should be given in simplest form, where relevant.

Write the make and model of your calculator(s) here:

Answer **all six** questions from this section.

Question 1**(25 marks)**

Katie tossed a coin 200 times and threw 109 heads. Joe tossed the same coin 400 times and threw 238 heads. Lucy tossed the same coin 500 times and threw 291 heads. Katie, Joe and Lucy now think the coin may be biased.

- (a) Give a reason why they think that the coin may be biased.

Each player tosses more than 50% heads.

- (b) Lucy uses all the above data and calculates that the best estimate of the probability of throwing a head with this coin is 0.58. Show how Lucy might have calculated this probability.

Number of heads tossed: $109 + 238 + 291 = 638$

Total numbers of tosses: $200 + 400 + 500 = 1100$

$$P(\text{head}) = \frac{638}{1100} = 0.58$$

- (c) Joe agrees with Lucy's estimate of 0.58 as the probability of throwing a head with this coin. He claims that the probability of throwing 3 successive heads with this coin is **less** than the probability of throwing 2 successive tails. Calculate the probability of each event and state whether Joe's claim is true or not.

$$P(3 \text{ heads}) = 0.58^3 \approx 0.195$$

$$P(2 \text{ tails}) = 0.42^2 \approx 0.176$$

Joe's claim is not true.

Question 2

(25 marks)

An unbiased circular spinner has a movable pointer and five equal sectors, two coloured green and three coloured red.

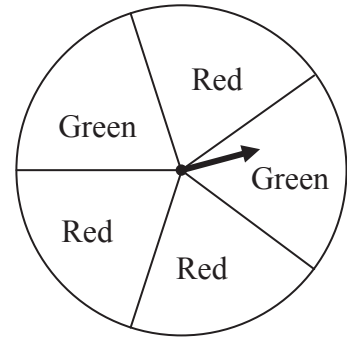

- (a) (i) Find the probability that the pointer stops on green for one spin of the spinner.

$$P(\text{Green}) = \frac{2}{5}$$

- (ii) List all the possible outcomes of three successive spins of the spinner.

- RRR
- RRG
- RGR
- GRR
- RGG
- GRG
- GGR
- GGG

- (b) A game consists of spinning the spinner 3 times. Each time the spinner stops on green the player wins €1, otherwise the player wins nothing. For example, if the outcome of one game is “green, red, green” the player wins €2.

Complete the following table:

Player wins	€0	€1	€2	€3
Required outcomes	RRR	RRG RGR GRR	RGG GRG GGR	GGG

- (c) Is one spin of the spinner above an example of a Bernoulli trial?

Answer: Yes

Explain what a Bernoulli trial is.

A Bernoulli trial is an experiment whose outcome is random and can be either of two possibilities: “success” or “failure”.

Question 3**(25 marks)**

- (a) l is the line $3x + 2y + 18 = 0$. Find the slope of l .

$$3x + 2y + 18 = 0 \Rightarrow 2y = -3x - 18 \Rightarrow y = -\frac{3}{2}x - 9$$

$$\text{Slope} = -\frac{3}{2}$$

- (b) The line k is perpendicular to l and cuts the x -axis at the point $(7, 0)$. Find the equation of k .

$$k \perp l \Rightarrow m \times -\frac{3}{2} = -1 \Rightarrow m = \frac{2}{3}$$

$$y - y_1 = m(x - x_1)$$

$$k: y - 0 = \frac{2}{3}(x - 7) \Rightarrow 3y = 2x - 14 \Rightarrow 2x - 3y - 14 = 0$$

- (c) Find the co-ordinates of the point of intersection of the lines l and k .

$$\begin{array}{rcl} 3x + 2y = -18 & & 9x + 6y = -54 \\ 2x - 3y = 14 & \Rightarrow & \underline{4x - 6y = 28} \\ & & 13x = -26 \Rightarrow x = -2 \end{array}$$

$$3x + 2y = -18 \Rightarrow 3(-2) + 2y = -18 \Rightarrow 2y = -12 \Rightarrow y = -6$$

$$\text{Co-ordinates: } (-2, -6)$$

Question 4**(25 marks)**

The point A has co-ordinates $(8, 6)$ and O is the origin.

The diagram shows two circles c_1 and c_2 .

c_1 has centre $(0, 0)$ and radius $|OA|$.

c_2 has a diameter of $[OA]$.

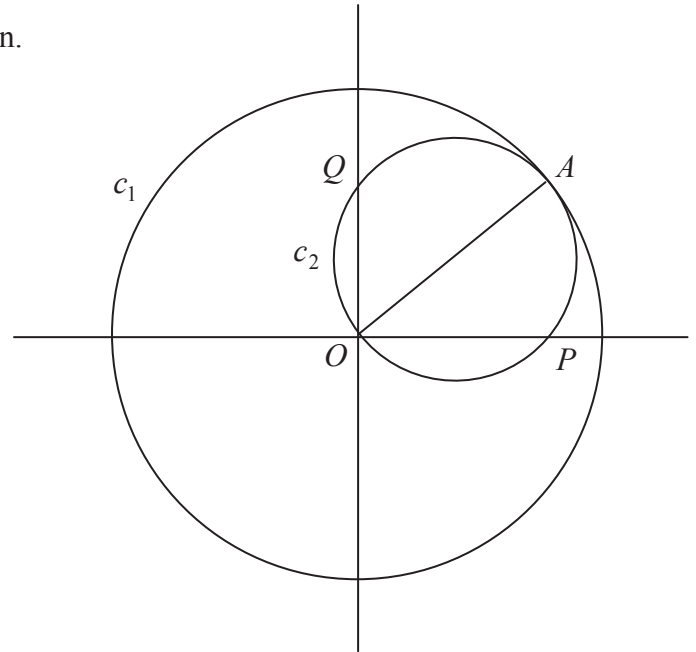

- (a) Find the equation of c_1 .

$$\begin{aligned}
 |OA| &= \sqrt{(8-0)^2 + (6-0)^2} \\
 &= \sqrt{64+36} = \sqrt{100} = 10 \\
 x^2 + y^2 &= 10^2 = 100
 \end{aligned}$$

- (b) Find the equation of c_2 .

$$\begin{aligned}
 \left(\frac{8+0}{2}, \frac{6+0}{2} \right) &= (4, 3) \\
 (x-4)^2 + (y-3)^2 &= 5^2 = 25
 \end{aligned}$$

- (c) The circle c_2 cuts the x -axis at the point P . Find the co-ordinates of P .

$$\begin{aligned}
 (x-4)^2 + (y-3)^2 &= 25 \\
 y=0 &\Rightarrow (x-4)^2 + (0-3)^2 = 25 \Rightarrow (x-4)^2 = 25-9=16 \\
 &\Rightarrow x-4 = \pm 4 \Rightarrow x=8 \text{ or } x=0 \\
 \text{Co-ordinates of } P: & \quad (8, 0)
 \end{aligned}$$

Question 5

(25 marks)

A solid cylinder has a radius of 10 mm and a height of 45 mm.

- (a) Draw a sketch of the net of the surface of the cylinder and write its dimensions on the sketch.

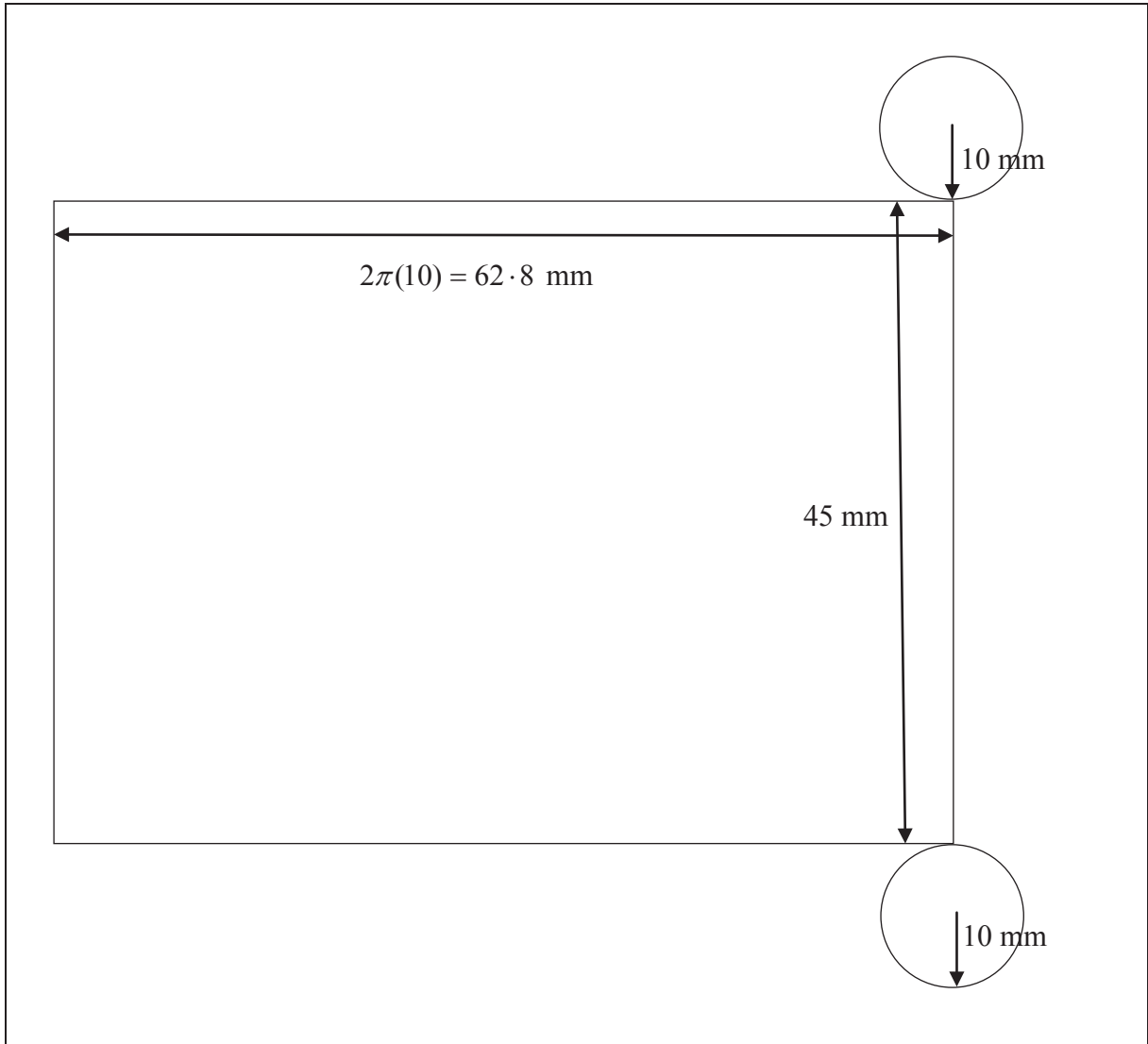

- (b) Calculate the volume of the cylinder. Give your answer in terms of π .

$$V = \pi r^2 h = \pi(10)^2(45) = 4500\pi \text{ mm}^3$$

- (c) A sphere has the same volume as the cylinder.
Find the surface area of the sphere. Give your answer in terms of π .

$$\begin{aligned}\frac{4}{3}\pi r^3 &= 4500\pi \\ \Rightarrow r^3 &= \frac{4500 \times 3}{4} = 3375 \\ \Rightarrow r &= \sqrt[3]{3375} = 15 \text{ mm} \\ A &= 4\pi r^2 = 4\pi(15)^2 = 900\pi \text{ mm}^2\end{aligned}$$

Question 6

(25 marks)

Answer **either** 6A **or** 6B.

Question 6A

- (a) Construct the triangle ABC such that $|AB| = 8$ cm, $|BC| = |AC| = 5$ cm. The point A is given to you.

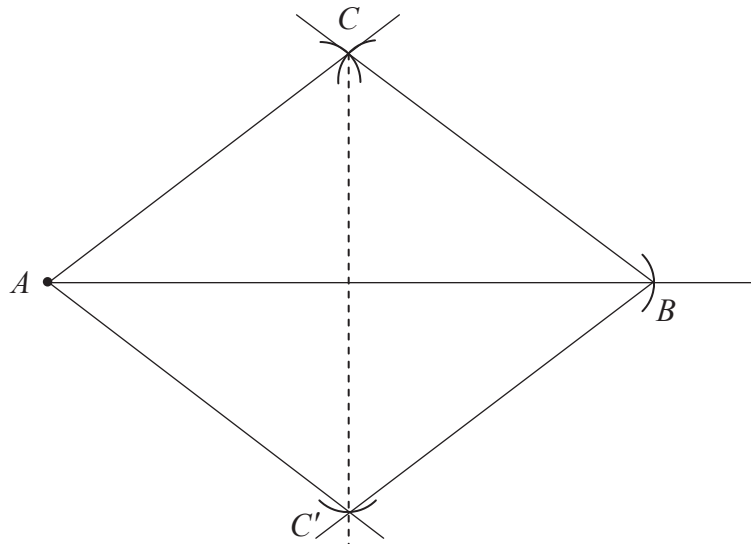

- (b) On the same diagram, construct the image of the triangle ABC under the axial symmetry in AB .
- (c) Justify the statement “ $AC'BC$ is a parallelogram” where C' is the image of C under the axial symmetry in AB .

The diagonals $[AB]$ and $[CC']$ of $AC'BC$ bisect one another.

Hence, $AC'BC$ is a parallelogram.

OR

Question 6B

In the acute-angled triangle ABC

$AP \perp BC$, $BQ \perp AC$ and $CR \perp AB$.

Prove that

$$|\angle ABQ| + |\angle BCR| + |\angle CAP| = 90^\circ.$$

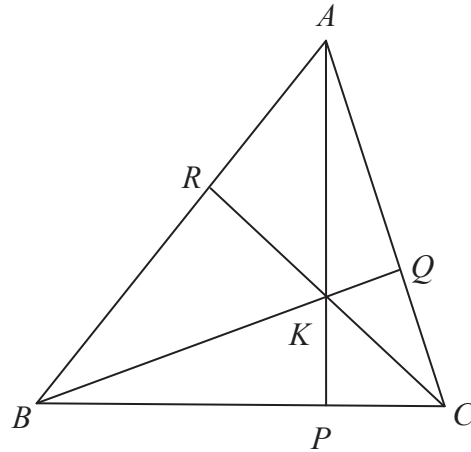

In the triangle APC ,

$$|\angle CAP| + |\angle PCA| = 90^\circ \quad \dots |\angle APC| = 90^\circ.$$

In the triangle QBC ,

$$|\angle QBC| + |\angle BCQ| = 90^\circ \quad \dots |\angle CQB| = 90^\circ.$$

Hence, $|\angle CAP| = |\angle QBC|$.

In the triangle RBC ,

$$|\angle RBC| + |\angle BCR| = 90^\circ \quad \dots |\angle CRB| = 90^\circ$$

$$\Rightarrow |\angle RBQ| + |\angle QBC| + |\angle BCR| = 90^\circ$$

$$\Rightarrow |\angle ABQ| + |\angle CAP| + |\angle BCR| = 90^\circ.$$

Or

In $\triangle RBK$, $|\angle RBK| + |\angle BKR| + 90^\circ = 180^\circ$ Angle sum in a triangle is 180°

In $\triangle PCK$, $|\angle PCK| + |\angle CKP| + 90^\circ = 180^\circ$.

In $\triangle QAK$, $|\angle QAK| + |\angle AKQ| + 90^\circ = 180^\circ$.

Adding: $|\angle RBK| + |\angle BKR| + |\angle PCK| + |\angle CKP| + |\angle QAK| + |\angle AKQ| + 270^\circ = 540^\circ$

$$\Rightarrow |\angle RBK| + |\angle PCK| + |\angle QAK| = 540^\circ - 270^\circ - (|\angle BKR| + |\angle CKP| + |\angle AKQ|)$$

$$\Rightarrow |\angle RBK| + |\angle PCK| + |\angle QAK| = 270^\circ - (180^\circ) = 90^\circ$$

$$\Rightarrow |\angle ABQ| + |\angle BCR| + |\angle CAP| = 90^\circ.$$

Answer **both** Question 7 **and** Question 8.

Question 7**(75 marks)**

The table below shows the rates of births, marriages and deaths in Ireland from 1990 to 2010. The rates are per 10000 of the estimated population.

Number of Births, Marriages and Deaths in Ireland (per 10 000 of the estimated population)			
Year	Births	Marriages	Deaths
1990	151	51	90
1991	150	49	89
1992	144	47	87
1993	138	47	90
1994	135	46	86
1995	135	43	90
1996	140	45	87
1997	144	43	86
1998	146	45	85
1999	144	50	87
2000	145	51	83
2001	150	50	79
2002	155	52	76
2003	155	51	73
2004	153	52	71
2005	148	52	68
2006	154	52	67
2007	163	52	64
2008	168	50	63
2009	167	48	63
2010	165	46	61

(Foinse : An Phríomh-Oifig Staidrimh, <http://www.cso.ie>)

- (ii) The standard deviation of the death rates in the table over is $10 \cdot 3$. List all of the death rates that are within 1 standard deviation of the mean.

Range of 1 standard deviation about the mean:

$$[78 \cdot 3 - 10 \cdot 3, 78 \cdot 3 + 10 \cdot 3] = [68, 88 \cdot 6]$$

68, 71, 73, 76, 79, 83, 87, 85, 86, 87, 86, 87

- (e) In 2010, the number of children born in Ireland was 75 174. Use this number to estimate the total population of Ireland in 2010.

$$\frac{75\,174}{165} \times 10\,000 = 4\,556\,000$$

- (f) Use your answer to (e) to estimate the number of people who died in Ireland in 2010.

$$\frac{4\,556\,000}{10\,000} \times 61 = 27\,791$$

- (g) “More children were born in Ireland in 1990 than in 2000.” Give a reason, based on the data, why this statement is not necessarily true.

The birth rates given are per 10 000 of the population. If the population in 2000 was greater than in 1990, more children could have been born in 2000 than in 1990 even though the birth rate in 2000 was lower.

- (h) Find the ratio, Birth rate : Death rate, for the two years 1990 and 2010. Based on your answers for the two years, what would you predict about the population of Ireland in future years. Give a reason for your answer.

1990 Ratio: 151 : 90 2010 Ratio: 165 : 61

Prediction: The population of the country is expected to increase.

Reason: The increase in the ratio from 1990 to 2010 suggests that more children are being born for each person that dies.

- (i) The birth rate and death rate over the 21 years are plotted against each other in the scatter plot below. The correlation coefficient between the two sets of data is -0.85 . Describe the relationship between the two sets of data and suggest a reason why this might be the case.

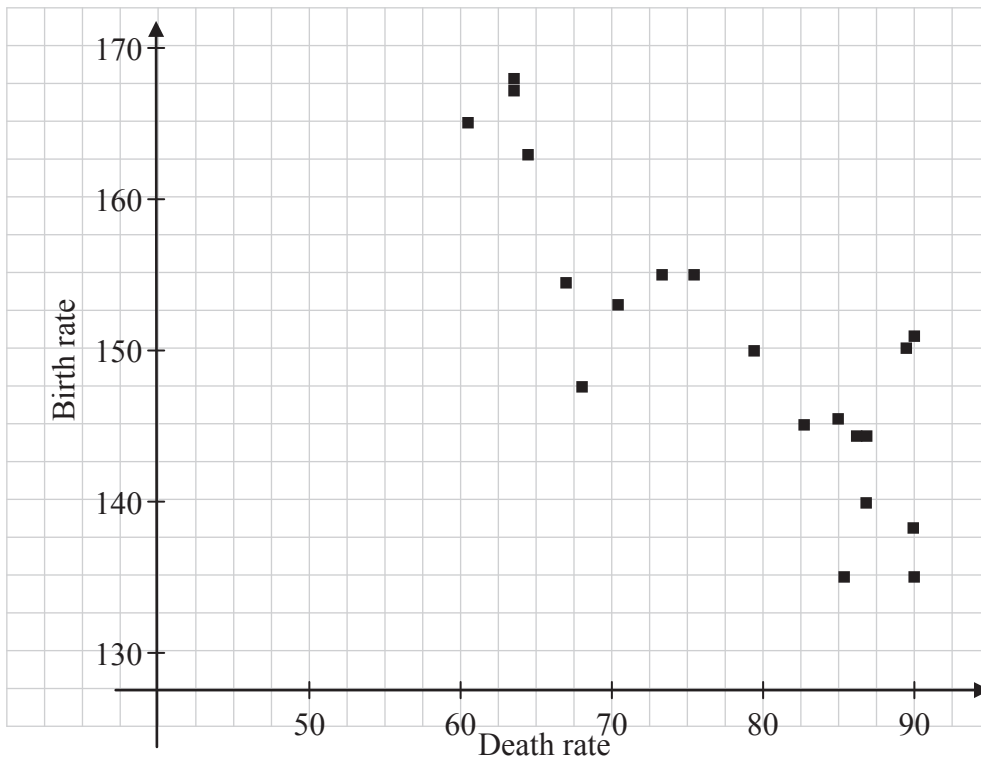

Strong negative correlation

With the increasing birth rate, the population is getting younger and the death rate is declining.

Question 8**(75 marks)**

A search is begun for a buoy that has become detached from its mooring at sea. The area to be searched is a circle of radius 30 km from the last known position, K , of the buoy. The search area is divided into six equal sectors as indicated by the letters A, B, C, D, E and F .

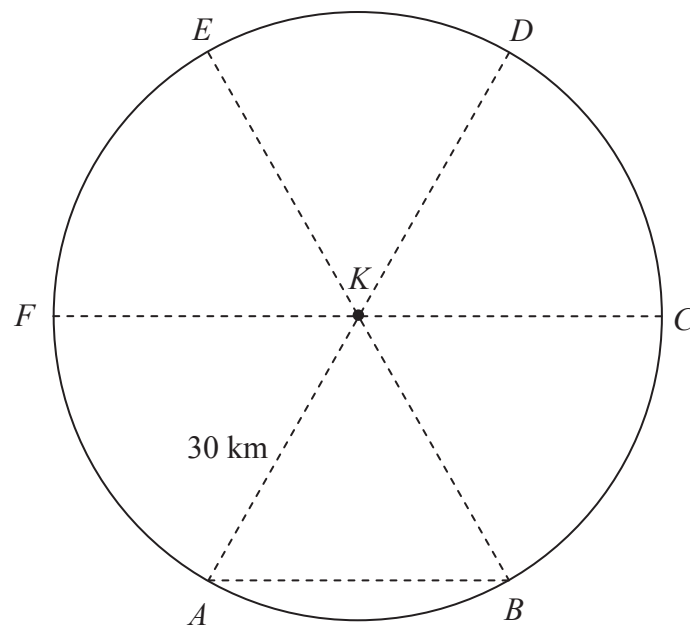

(a) Fishing boats search the triangular area KAB .

(i) Find $|\angle BKA|$.

$$|\angle BKA| = 360^\circ \div 6 = 60^\circ$$

(ii) Find the area of the triangle KAB .

$$\text{Area} = \frac{1}{2} ab \sin C = \frac{1}{2} \times 30 \times 30 \times \sin 60^\circ = 389.7 \text{ km}^2$$

(iii) Write the area of the triangle KAB as a percentage of the area of the sector KAB .

$$\text{Area of sector: } \frac{1}{6} \pi r^2 = \frac{1}{6} \pi (30)^2 = 471.24 \text{ km}^2$$

$$\frac{389.7}{471.24} \times 100 = 82.7\%$$

(iv) Use the cosine rule to find the length of $[AB]$.

$$a^2 = b^2 + c^2 - 2bc \cos A$$

$$|AB|^2 = 30^2 + 30^2 - 2(30)(30) \cos 60^\circ = 900 \Rightarrow |AB| = 30 \text{ km}$$

(v) What does your answer to (iv) above show about the triangle KAB ?

The triangle KAB is an equilateral triangle.

(b) A helicopter took part in the search.

- (i) The helicopter flew from the point F around the perimeter of the search area. What distance did the helicopter fly, correct to the nearest km?

$$2\pi r = 2\pi \times 30 = 188.49 \approx 188 \text{ km}$$

- (ii) The helicopter then flew in a straight line from F to D and from D on to C , also in a straight line. Draw the path of the helicopter on the diagram.

- (iii) A theorem on your course can be used to find $|\angle FDC|$. Write down $|\angle FDC|$ and state the theorem.

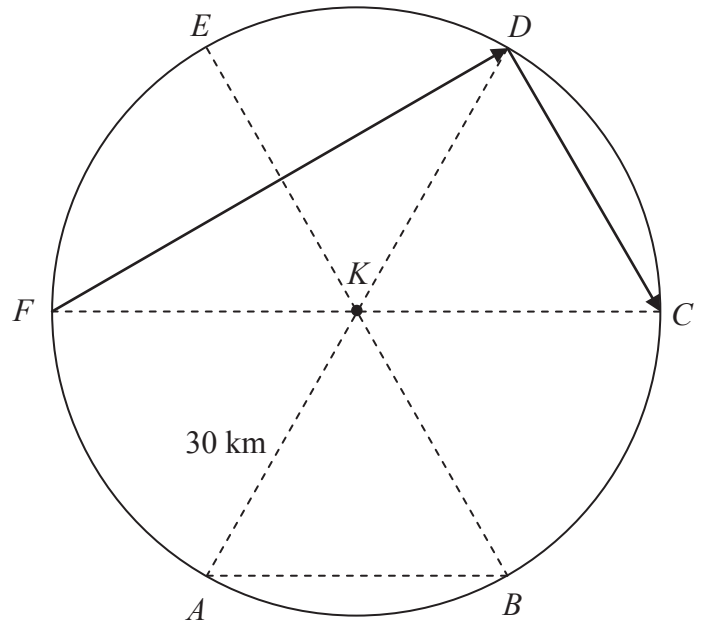

$$|\angle FDC| = 90^\circ$$

The angle in a semicircle is a right-angle.

- (iv) The helicopter flew at a speed of 80 km/h. How long did it take to fly from F to D and on to C ?

$$\cos 30^\circ = \frac{|FD|}{60} \Rightarrow |FD| = 60 \cos 30^\circ = 51.96 \text{ km}$$

$$|FD| + |DC| = 51.96 + 30 = 81.96 \text{ km}$$

$$\text{Time: } \frac{81.96}{80} = 1.0245 \text{ hours}$$

(c) A lifeboat taking part in the search sailed, in a straight line, from the point K until it reached a point X , the midpoint of $[ED]$.

(i) Calculate $|KX|$.

$$\Delta KXE : \cos 30^\circ = \frac{|KX|}{30} \Rightarrow |KX| = 30 \cos 30^\circ = 25.98 \text{ km}$$

Or

$$\begin{aligned} |KX|^2 + |XE|^2 &= |EK|^2 \\ \Rightarrow |KX|^2 &= |EK|^2 - |XE|^2 = 30^2 - 15^2 = 675 \Rightarrow |KX| = 25.98 \text{ km} \end{aligned}$$

(ii) The buoy was located at the point where the path KX , of the lifeboat, crossed the path FD of the helicopter. How far was the buoy from X ?

$$KX \cap FD = \{P\}$$

$$\Delta DXP : \tan 30^\circ = \frac{|XP|}{15} \Rightarrow |XP| = 15 \tan 30^\circ = 8.66 \text{ km}$$

Or

$$\Delta FKP : \tan 30^\circ = \frac{|KP|}{30} \Rightarrow |KP| = 30 \tan 30^\circ = 17.32 \text{ km}$$

$$|XP| = 25.98 - 17.32 = 8.66 \text{ km}$$

Marking Scheme – Paper 2, Section A and Section B

Structure of the marking scheme

Candidate responses are marked according to different scales, depending on the types of response anticipated. Scales labelled A divide candidate responses into two categories (correct and incorrect). Scales labelled B divide responses into three categories (correct, partially correct, and incorrect), and so on. The scales and the marks that they generate are summarised in this table:

Scale label	A	B	C	D
No of categories	2	3	4	5
5 mark scales		0, 3, 5	0, 3, 4, 5	
10 mark scales			0, 4, 7, 10	0, 2, 5, 8, 10
15 mark scales				0, 4, 7, 11, 15
25 mark scales				0, 6, 12, 19, 25

A general descriptor of each point on each scale is given below. More specific directions in relation to interpreting the scales in the context of each question are given in the scheme, where necessary.

Marking scales – level descriptors

A-scales (two categories)

- incorrect response
- correct response

B-scales (three categories)

- response of no substantial merit
- partially correct response
- correct response

C-scales (four categories)

- response of no substantial merit
- response with some merit
- almost correct response
- correct response

D-scales (five categories)

- response of no substantial merit
- response with some merit
- response about half-right
- almost correct response
- correct response

In certain cases, typically involving incorrect rounding or omission of units, a mark that is one mark below the full-credit mark may also be awarded. Such cases are flagged with an asterisk. Thus, for example, *scale 10C** indicates that 9 marks may be awarded.

Summary of mark allocations and scales to be applied

Section A

Question 1	
(a)	5B
(b)	10C
(c)	10C

Question 2	
(a)	10C
(b)	10C
(c)	5C

Question 3	
(a)	10C
(b)	10C
(c)	5C

Question 4	
(a)	5C
(b)	10D
(c)	10C

Question 5	
(a)	5C*
(b)	10C*
(c)	10D*

Question 6A	
(a)	10C
(b)	10C
(c)	5B

Question 6B	
	25D

Section B

Question 7	
(a)	15D
(b)	5B
(c)	10C
(d) (i)	10C*
(d) (ii)	5C
(e)	5C
(f)	5C
(g)	5B
(h)	10C
(i)	5B

Question 8	
(a) (i)	5B
(a) (ii)	10C*
(a) (iii)	10C
(a) (iv)	10C*
(a) (v)	5B
(b) (i)	5C*
(b) (ii)	5B
(b) (iii)	5B
(b) (iv)	10C*
(c) (i)	5C*
(c) (ii)	5C*

Detailed marking notes

Section A

Question 1

(a) Scale 5B (0, 3, 5)

Partial credit:

- States one or two players throw more heads than tails.
- Gives an indication that $109 > 100$ or $238 > 200$.

(b) Scale 10C (0, 4, 7, 10)

Low partial credit:

- Finds the correct total number of heads or throws.
- Calculates the correct probability for one player.

High partial credit:

- Finds the total number of heads and throws.
- Calculates the probability using the totals but one element of the fraction incorrect.
- Calculates the correct probability for each of the three players individually.

(c) Scale 10C (0, 4, 7, 10)

Low partial credit:

- Writes the correct probability for three heads or two tails.
- Calculates the correct probability for three heads and two tails using a fair coin.

High partial credit:

- Calculates the correct probability for three heads and two tails but with an incorrect or omitted statement.
- Fully correct answer using a fair coin.

Question 2

(a) Scale 10C (0, 4, 7, 10)

Low partial credit:

- Relevant work in one section e.g. states two green sectors or gives GGG as a possible outcome.

High partial credit:

- One section correct.
- Substantially correct work in both sections.

(b) Scale 10C (0, 4, 7, 10)

Note: Accept answers consistent with candidate's answers listed in (a)(ii).

Low partial credit:

- One correct or consistent outcome written.

High partial credit:

- One correct outcome for each category.
- At least five outcomes in total from a(ii).

(c) Scale 5C (0, 3, 4, 5)

Low partial credit:

- A correct response without an explanation of some merit.
- An incorrect response but some merit in the explanation.

High partial credit:

- A correct response with one aspect of the explanation correct.
- An incorrect response with a correct explanation.

Question 3

(a) Scale 10C (0, 4, 7, 10)

Low partial credit:

- Writes $y = mx + c$ and stops.
- Writes a relevant slope formula and stops.
- Some correct work at transposing terms.
- Finds one or two points on l .

High partial credit:

- Equation of the line written in the form $y = mx + c$ but slope not identified.
- Finds the slope of l using two points, one of which is incorrect.

Note: A correct answer without work shown, award full credit.

(b) Scale 10C (0, 4, 7, 10)

Low partial credit:

- Identifies correct relevant formula, e.g. writes $y - y_1 = m(x - x_1)$ and stops.
- Writes correct or consistent slope for k .
- Some correct work with (7, 0).

High partial credit:

- Substitution into the line equation with one error.

Note: A correct answer without work shown, award full credit.

(c) Scale 5C (0, 3, 4, 5)

Low partial credit:

- Relevant work towards equating coefficients in both equations.
- Relevant work towards substituting for one variable using the other equation.
- One line correctly graphed.

High partial credit:

- One correct or consistent co-ordinate found.
- One or two algebraic errors leading to an incorrect point of intersection.
- A correct structure to the solution with up to two errors.
- A correct answer, obtained graphically.

Question 4

(a) Scale 5C (0, 3, 4, 5)

Low partial credit:

- Writes a correct distance formula or formula for the equation of the circle.

High partial credit:

- Calculates the distance O to A .
- Substitutes into correct circle formula with one error.
- Calculates r^2 incorrectly.

Note: A correct answer without work shown, award full credit.

(b) Scale 10D (0, 2, 5, 8, 10)

Low partial credit:

- Writes a correct midpoint formula or formula for the equation of the circle.
- Writes the midpoint or radius correctly.

Middle partial credit:

- Writes the midpoint and radius correctly.
- Substitutes the centre or radius into the equation.

High partial credit:

- Substitutes the centre and radius into the equation.
- Substitutes into correct circle formula with one error.
- Calculates r^2 incorrectly.

(c) Scale 10C (0, 4, 7, 10)

Low partial credit:

- Identifies that $y = 0$.
- Some relevant substitution into the equation.
- Correct answer without work shown.

High partial credit:

- Substantially correct work at solving for x , e.g. works incorrectly with $(x - 4)^2 = 16$.
- Correct answer without the co-ordinates of P identified.

Note: A correct answer with a correct geometrical explanation, award full credit.

Question 5

(a) Scale 5C* (0, 3, 4, 5)

Low partial credit:

- A rectangle or a circle drawn.
- The length of the circle calculated.

High partial credit:

- A correct sketch drawn without dimensions.
- A partially complete sketch drawn with some dimensions given.

* Penalise one mark for incorrect or omitted units, provided full marks otherwise.

(b) Scale 10C* (0, 4, 7, 10)

Low partial credit:

- Correct formula for the volume of a cylinder written and stops.
- An incorrect relevant formula and some correct substitution.

High partial credit:

- Formula substituted correctly without calculation or with incorrect calculation.
- Some incorrect substitution into formula with correct calculation.
- Correct answer not expressed in terms of π .

* Penalise one mark for incorrect or omitted units, provided full marks otherwise.

Note: A correct answer without work shown, award full credit.

(c) Scale 10D* (0, 2, 5, 8, 10)

Low partial credit:

- Writes correct formula for the volume or surface area of a sphere.
- Equates volume of cylinder with surface area of sphere.

Middle partial credit:

- Equates volume of cylinder with volume of sphere.
- Equates volume of cylinder with surface area of sphere and correctly calculates r .

High partial credit:

- Calculates the radius of the sphere.
- Calculates correctly an incorrect surface area.
- Calculates the correct surface area with an incorrect radius.
- Correct answer not expressed in terms of π .

* Penalise one mark for incorrect or omitted units, provided full marks otherwise.

Question 6A

(a) Scale 10C (0, 4, 7, 10)

Low partial credit:

- Point *B* or *C* correctly marked on the given line.
- One arc drawn for a point not on the line.
- Freehand triangle drawn with dimensions.

High partial credit:

- Point *B* found and one arc for *C* drawn.
- Correct triangle drawn but construction lines not shown.
- Points *B* and *C* constructed but sides not drawn.
- Triangle constructed correctly but measurements not exact.

(b) Scale 10C (0, 4, 7, 10)

Low partial credit:

- Freehand image drawn.
- Relevant work at constructing the image of *C*.

High partial credit:

- Correct triangle drawn but construction lines not shown.

(c) Scale 5B (0, 3, 5)

Partial credit:

- Some correct element in the candidate's justification or an incomplete justification.

Question 6B

Scale 25D (0, 6, 12, 19, 25).

Low partial credit:

- Relevant work with the angle sum in one triangle.
- Correct identification of vertically opposite angles being equal.

Middle partial credit:

- Similar work with two relevant triangles.

High partial credit:

- A correct answer other than one step omitted or incorrect.

Section B

Question 7

(a) Scale 15D (0, 4, 7, 11, 15)

Low partial credit:

- A correct element of the plot entered.
- Key given without entering any elements.

Middle partial credit:

- One side of the plot correct without the key.
- Ten elements on each side correct, without the key.
- Ten elements in total correct, with the correct key.

High partial credit:

- A correct plot without the key.
- A plot with five or less elements incorrect with the correct key.
- Correct plot and key but data not ordered.

(b) Scale 5B (0, 3, 5)

Partial credit:

- A correct but incomplete difference given.

(c) Scale 10C (0, 4, 7, 10)

Low partial credit:

- Describes the median or interquartile range.
- Relevant work towards finding the median or the interquartile range.
- Writes the range of the marriage rate.

High partial credit:

- One correct answer.
- Substantially correct work in each part.
- Correct answers using the data for the birth rate or the death rate.

(d)(i) Scale 10C* (0, 4, 7, 10)

Low partial credit:

- Writes the formula for the mean.
- Finds the value of n or adds some of the elements.

High partial credit:

- Correct substitution into the formula without calculation.
- Incorrect substitution into the formula with calculation.

* Penalise one mark for incorrect or omitted roundoff, provided full marks otherwise.
[Accept 78 in this context.]

Note: A correct answer without work shown, award full credit.

- (d)(ii)** Scale 5C (0, 3, 4, 5)
Low partial credit:
- Finds one correct boundary.
- High partial credit:*
- Finds both correct boundaries without elements listed.
 - Finds one correct boundary with the correct elements.
- (e)** Scale 5C (0, 3, 4, 5)
Low partial credit:
- Identifies 165 as the birth rate or recognises the rate is per 10 000.
- High partial credit:*
- Correct fraction without calculation.
 - Fraction with one element incorrect, correctly calculated.
- (f)** Scale 5C (0, 3, 4, 5)
Low partial credit:
- Identifies 61 as the death rate.
 - Carries forward the answer from (e).
- High partial credit:*
- Correct fraction without calculation.
 - Fraction with one element incorrect, correctly calculated.
- (g)** Scale 5B (0, 3, 5)
Partial credit:
- A plausible reason with some relevant reference to the data.
- (h)** Scale 10C (0, 4, 7, 10)
Low partial credit:
- One correct ratio found.
 - A prediction with some merit.
 - Two correct ratios based on years rather than events.
- High partial credit:*
- Two correct ratios found and a prediction or a reason.
 - One correct ratio with some merit in the prediction and reason.
 - A prediction with a reason, both having merit.
- (i)** Scale 5B (0, 3, 5)
Partial credit:
- Relationship described as negative correlation.
 - Relevant reason about the population change.

Question 8

(a)(i) Scale 5B (0, 3, 5)

Partial credit:

- Six equal sectors identified or notes the angle at the centre is 360° .

Note: A correct answer without work shown, award full credit.

(a)(ii) Scale 10C* (0, 4, 7, 10)

Low partial credit:

- Writes a correct relevant formula.
- One or two correct substitutions into formula.

High partial credit:

- Correct or consistent substitution into formula.
- Incorrect answer from an incorrect calculator mode.

* Penalise one mark for incorrect or omitted units, provided full marks otherwise.

Note: A correct answer without work shown, award full credit.

(a)(iii) Scale 10C (0, 4, 7, 10)

Low partial credit:

- Writes a correct formula for area of sector.
- Some correct substitution into a correct relevant formula.

High partial credit:

- Correct area of sector.
- Fraction written with one error, calculated.

(a)(iv) Scale 10C* (0, 4, 7, 10)

Low partial credit:

- Formula for the cosine rule written.
- Some correct substitution.

High partial credit:

- A fully correct substitution, without complete and correct calculation.
- Substantially correct work in substitution and calculation.

* Penalise one mark for incorrect or omitted units, provided full marks otherwise.

(a)(v) Scale 5B (0, 3, 5)

Partial credit:

- Work of merit such as reference to two sides equal.

(b)(i) Scale 5C* (0, 3, 4, 5)

Low partial credit:

- Writes the correct formula.

High partial credit:

- Correct substitution into formula without complete and correct calculation.
- Incorrect substitution with correct calculation.
- An answer of 189 km with work.

* Penalise one mark for incorrect or omitted roundoff, provided full marks otherwise.

Note: A correct answer without work shown, award full credit.

(b)(ii) Scale 5B (0, 3, 5)

Partial credit:

- One correct line drawn.

(b)(iii) Scale 5B (0, 3, 5)

Partial credit:

- Relevant work such as $|\angle FDC|$ indicated correctly.

(b)(iv) Scale 10C* (0, 4, 7, 10)

Low partial credit:

- Calculates or gives one correct distance.

High partial credit:

- Calculates the total distance.
- Sets up correct fraction to calculate time without complete and correct calculation.
- Sets up incorrect fraction to calculate time with correct calculation.

* Penalise one mark for incorrect or omitted units, provided full marks otherwise.

(c)(i) Scale 5C* (0, 3, 4, 5)

Low partial credit:

- Draws a line from K to X or notes additional relevant work on the diagram.
- Correct trigonometric ratio set up.
- Correct application of theorem of Pythagoras written.

High partial credit:

- A fully correct substitution, without complete and correct calculation.
- One error in substitution with fully correct calculation.

* Penalise one mark for incorrect or omitted units, provided full marks otherwise.

(c)(ii) Scale 5C* (0, 3, 4, 5)

Low partial credit:

- Indicates the required point on the diagram.
- Correct trigonometric ratio set up or similar work of merit.

High partial credit:

- A fully correct substitution, without complete and correct calculation.
- One error in substitution with fully correct calculation.

* Penalise one mark for incorrect or omitted units, provided full marks otherwise.

Marcanna Breise as ucht Freagairt trí Ghaeilge

(Bonus marks for answering through Irish)

Ba chóir marcanna de réir an ghnáthráta a bhronnadh ar iarrthóirí nach ngnóthaíonn níos mó ná 75% d'iomlán na marcanna don pháipéar. Ba chóir freisin an marc bónais sin a shlánú **síos**.

Déantar an cinneadh agus an ríomhaireacht faoin marc bónais i gcás gach páipéir ar leithligh.

Is é 5% an ghnáthráta agus is é 300 iomlán na marcanna don pháipéar. Mar sin, bain úsáid as an ngnáthráta 5% i gcás iarrthóirí a ghnóthaíonn 225 marc nó níos lú, e.g. $198 \text{ marc} \times 5\% = 9.9 \Rightarrow$ bónas = 9 marc.

Má ghnóthaíonn an t-iarrthóir níos mó ná 225 marc, ríomhtar an bónas de réir na foirmle $[300 - \text{bunmharc}] \times 15\%$, agus an marc bónais sin a shlánú **síos**. In ionad an ríomhaireacht sin a dhéanamh, is féidir úsáid a bhaint as an tábla thíos.

Bunmharc	Marc Bónais
226	11
227 – 233	10
234 – 240	9
241 – 246	8
247 – 253	7
254 – 260	6
261 – 266	5
267 – 273	4
274 – 280	3
281 – 286	2
287 – 293	1
294 – 300	0

Blank Page

Blank Page

